

HEAT SEALER C2

C2 SYSTEM



This unit completes and extends the fresh product counter packaging options offered by the C1 SYSTEM, permitting use of a further series of containers and trays.

It provides great operating safety together with easy and efficient use and ensures sealed packaging for maximum product hygiene and protection. This is an indispensable unit for Operators wishing to upgrade and offer top-quality Counter Service to their customers.

TECHNICAL FEATURES

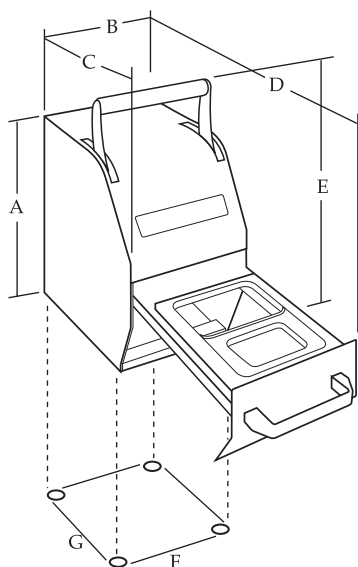

Total weight: 45 Kg approx. (without reel)

Power supply: single-phase – earth

Power voltage: 220 V \pm 10%

Power frequency: 50 Hz

Installed power: 900 W

Equivalent continuous sound radiation pressure under normal working conditions at a distance of 1 m is:

Leq(A) < 70 db(A)

Peak sound radiation pressure is: Lpe < 63 Pa

OVERALL DIMENSIONS:

A: 470mm

C: 425mm

E: 620mm

B: 270mm

D: 755mm

MINIMUM DIMENSIONS OF WORKTABLE:

F: 240mm

G: 295mm

Above reported data are indicative.

The manufacturer reserves the right to make any technical changes for the purpose of upgrading the machine, without notice.

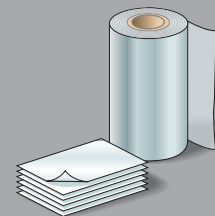

COMPAC
COMMERCIALE PACKAGING



OPERATING SPECIFICATIONS

C2 SYSTEM

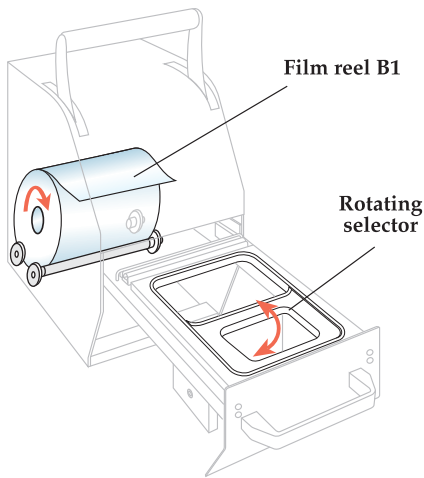

Simple and easy film reel fitting and removal. Simply lay the reel on the rollers once the drawer has been pulled out.

Rotating selector for sealing series P1 - P2 containers with their respective sheets.

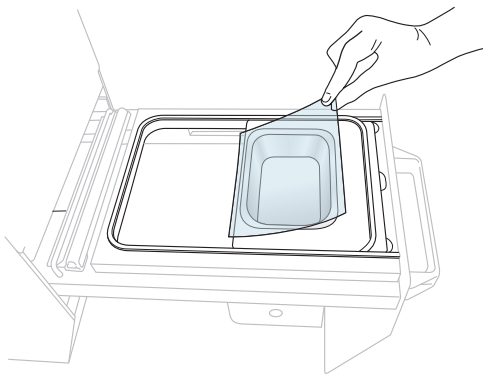
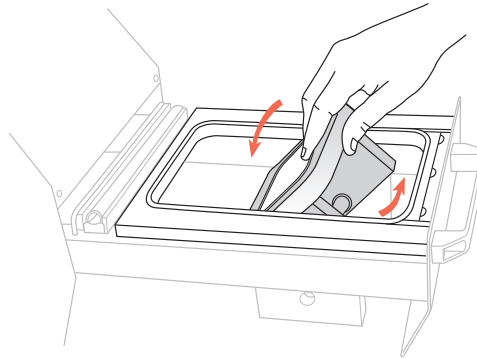

Pull-out drawer for total operating safety, with sliding selector for choosing the desired size of Series G - L - M containers or trays.

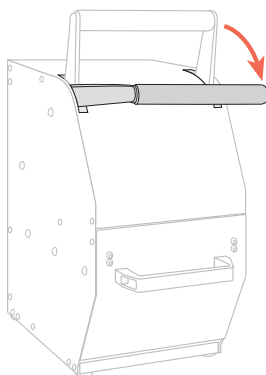
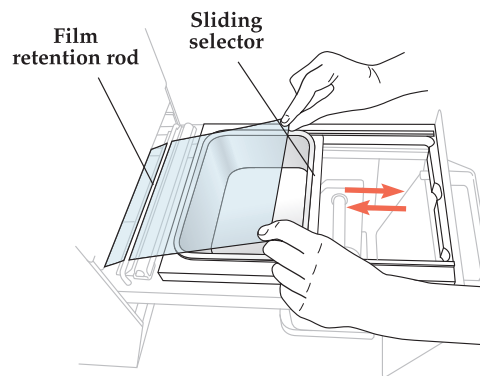

Film sealing cycle with automatic cutting. To start the cycle, simply lower the lever as far as it will go and then release. It will then elevate automatically in a few seconds, after sealing operation has been completed.

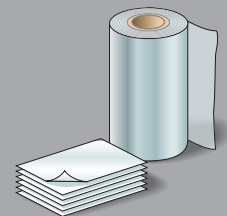

COMPAC
COMMERCIALE PACKAGING

42024 Castelnovo di Sotto (RE) ITALY - Tel. +39. 0522.688.509 - Fax +39.0522.688.552
www.compac.it - e-mail: compac@tin.it

